

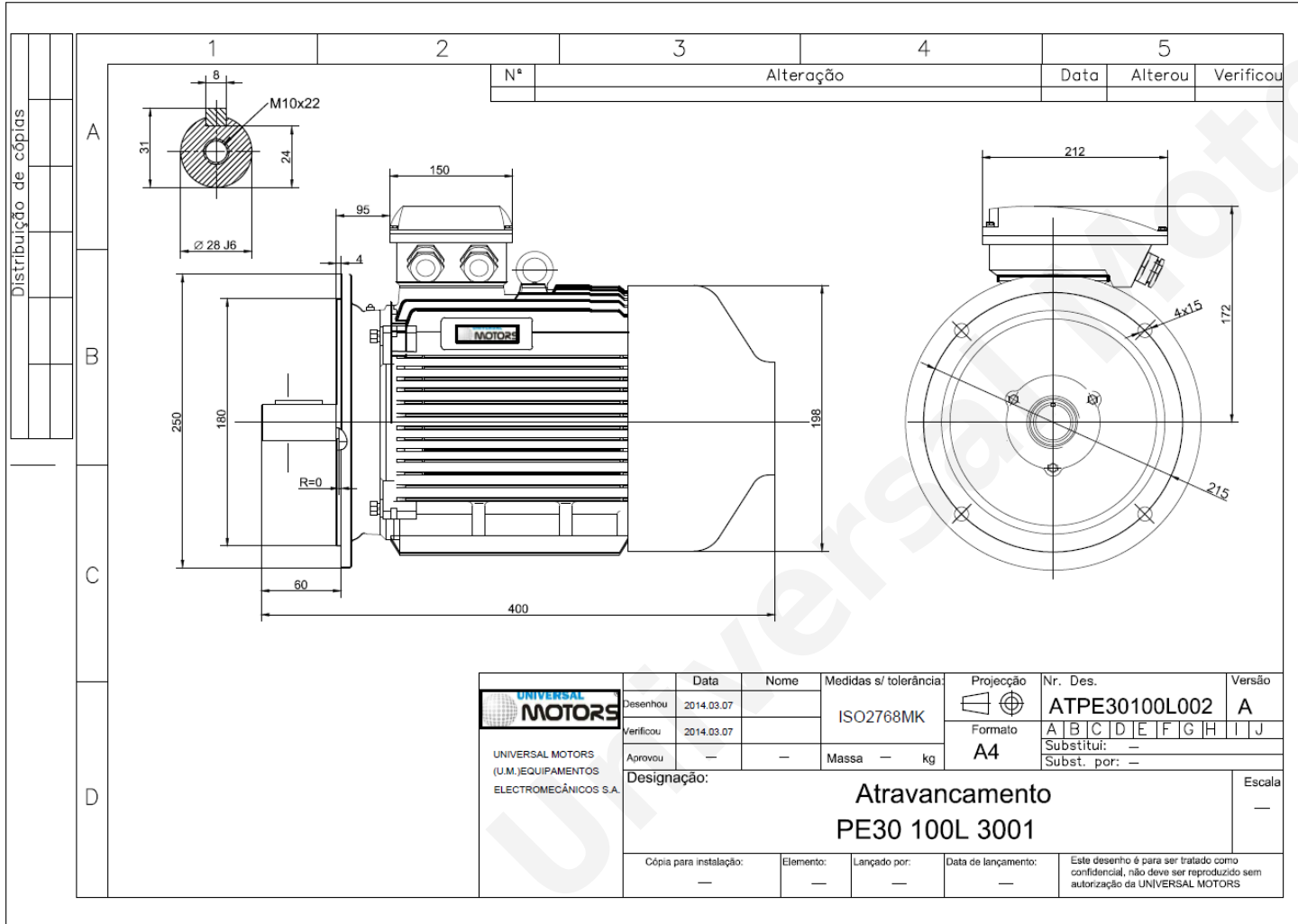

TECHNICAL DATA

Three Phase Electric Motors - Cast Iron Frame
 PE30 100 L 6 IE3
 1.5 kW / 2.0 Cv
 955 RPM



Motor type: **PE30 100 L 6 IE3**
 Output: **1.5 kW / 2.0 Cv**
 Speed (min⁻¹): **955 RPM**
 Frequency: **50 Hz**
 Voltage: **400 V**
 Current: **3.60 A**
 Power factor (Cos Ø): **0.73**
 Poles: **6**
 Insulation class: **F**
 Temperature rise Class: **B**
 Efficiency 50%: **81.7 %**
 Efficiency 75%: **83.4 %**
 Efficiency 100%: **82.7 %**
 Torque: **15 N.m**
 Tstarting/Tnominal: **2.0**
 Istarting/Inominal: **6.5**
 Tmaximum/Tnominal: **2.1**
 Noise: **50 Db(A)**
 Weight: **39 Kg**
 Bearing DE: **6206 2Z C3**
 Bearing NDE: **6206 2Z C3**

Regime - S1

Altitude - 1000m

Environment Temperature - 40°C

CONTACTS:

UNIVERSAL MOTORS Tel: +351 252 299 080
 Rua de São Brás,745 Fax: +351 252 299 089
 4480-782 VILA DO CONDE Mail: geral@universalmotors.pt

* References applied only in the UK